



TREEMME MM200B

 **TREEMME**
MERLO GROUP

MM200B FEATURES

ENGINE

Deutz 6 -cylinder turbo diesel intercooler common rail, 150 kW, 2300 rpm, displacement 6.1 l, Tier III A, liquid-cooled, electronic rpm control, on silent blocks.
Air flow inversion for dust removal from the radiator grille.

TRANSMISSION

Hydrostatic, with variable displacement pump and motor, electronic control, two-speed gearbox with electro-hydraulic engagement control.

Two displacement systems:

- 1) Automotive road type. Combined variation of engine rpm and forward speed through accelerator pedal;
- 2) Work. Engine rpm control by hand accelerator and forward speed control by accelerator pedal or potentiometer on joystick.

Speed:

1st speed (hare): 0-40 km/h forward/reverse;

2nd speed (turtle): 0-15 km/h forward/reverse;

3rd speed (duble turtle): 0-5 km/h forward/reverse in Work mode only.

STEERING

Four different steering modes:

- on front wheels;
- pivot steering;
- crab steering;
- on the rear wheels (OPT).

DRIVE

Permanent 4-wheel drive

AXLES

Front axle: Dana 223 type, fixed with reducers, built-in steering cylinders and planetary gearboxes.

Rear axle: Dana 212 type, oscillating with reducers, built-in steering cylinders and planetary gearboxes.

Full lock of the two electro-hydraulically controlled differentials.

SERVICE BRAKE

Wet discs, acting outside the differentials.

Foot pedal control, with double pump in the cab for dual circuit brake booster control.

PARKING BRAKE

Negative type, with hydraulic control, acting outside the differential of the front axle.

CHASSIS

High-resistance steel

TANKS

Hydraulic oil 200 l, with cooling.

Diesel 260 l.

Coolant 32 l.

Engine oil 16 l.

SERVICE HYDRAULIC SYSTEM

No. 1 "Load Sensing" pump for auxiliary controls.

Operating pressure: 230 bar. Flow and return filters.

Handler and 3rd point boom on proportional control distributor.

No. 1 Service line on ON-OFF control distributor.

FRONT TOOLBOX TRANSMISSION

Hydraulic with closed loop variable displacement pump. Maximum flow rate 285 l/min.

Maximum valve calibration pressure 420 bar.

CAB

ROPS, FOPS (level II) and OPS type-approved structure, insulated with anti-noise and anti-heat internal linings, fitted on silent blocks and hydraulically tiltable. 360° panoramic visibility. Continuous display of machine tilt angles. Joystick -type controls, with capacitive manipulator positioned on the right armrest of the seat. Courtesy LED light. Automatic air conditioner. Heating and ventilation. Heated air suspension seat with high backrest, adjustable in height and longitudinally, equipped with safety belts and armrests. Anti-shutter windscreen, transparent side windows in anti-shatter polycarbonate. Built-in LED work lights (4 at the front and 4 at the back). External removable rear-view mirrors. Removable bayonet mount rotating beacon. Front wiper. Radio. Safety rear window. Cabin pressurisation.

ELECTRIC SYSTEM

Voltage = 24 VDC - Batteries = no. 2 12VDC x 75 Ah (975 CCA minimum) - Generator = 80 A.

STANDARD TYRES

600/55-26.5 Trelleborg Twin Forestry T440, forest profile, reinforced discs, inflation valve protection.

FRONT TOOLBOX

Hydraulically operated handler, selectable in D.A/S.A. function, rigid with category 2 articulated couplings, Lifting force 4500 kg.
No. 1 double acting proportional service line, no. 1 ON/OFF service line.
Lift height: 1100 mm.

DEVICES AND ACCESSORIES ON REQUEST

Rear pull winch with towing force from 7.5 tonnes to 12.5 tonnes.
Rear axle oscillation lock.
Floating function and S/A of the front handler that can be operated by means of a push button on joystick.
Right side wipers.
Second removable beacon.
Arctic climate starting device (engine coolant preheating).
Use of biodegradable hydraulic oil, type Panolin HP46.
Air compressor for cleaning radiators.
Rear-view camera.

UNLADEN WEIGHT

MM200B: 8.000 kg.

TYPE APPROVALS AND CERTIFICATIONS

Forestry machine according to ISO 11850.

DIMENSIONS

	MM200B	
A (mm)	5330	
B (mm)	1140	
C (mm)	2650	
D (mm)	1540	
E (mm)	470*	
F (mm)	515*	
H (mm)	2470*	
M (mm)	1200	
P (mm)	3060*	

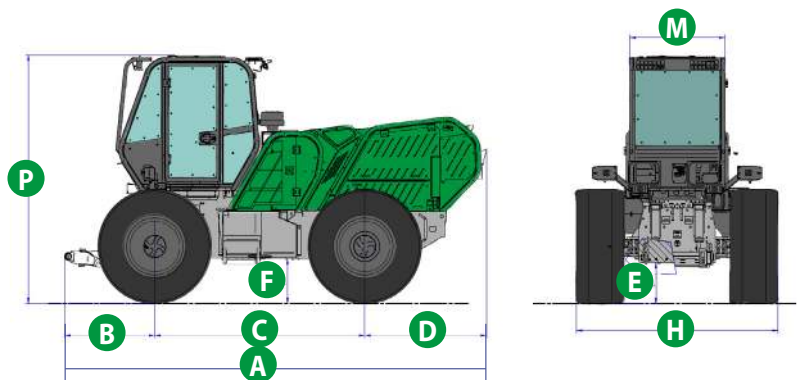

* dimensions E, F, H, P with TRELLEBORG 600/55-26,5 TWIN FORESTRY T440 wheels

** without winch

*** cabin exterior dimension



MERLO GROUP AUSTRALIA PTY LTD

27 Colin Jamieson Dve, Welshpool (Perth), WA 6106
Tel. (08) 9358 3110 - Fax (08) 9358 4110

120 Toongabbie Road, Girraween, NSW 2145
Tel. (02) 9688 0600

Tel:1300 657 325

info@merloaustralia.com.au
www.merloaustralia.com.au

DS_MM200B_0222_AUS

Your Merlo dealer



SYDNEY: Unit 6 2/10 Dunn Rd, Smeaton Grange NSW 2567

CANBERRA: 1 Paterson Parade, Queanbeyan West NSW 2620

WOLLONGONG: 6 Mineral Rd, Oak Flats NSW 2529

(02) 4728 7500

sales@stmequipment.com.au