

 **FUSO**
eCANTER
NEXT GEN
e918 Wide Cab Long Range
8.55t / Large Battery Pack



THE NEXT GEN ECANTER IS FUSO'S LATEST ELECTRIC TRUCK, WITH A NEW FACE LIFT ON BOTH THE INTERIOR AND EXTERIOR AND A WHOLE RANGE OF OPTIONS THE NEXT GEN IS READY FOR ANYTHING.

GVM

8550_{KG}

BATTERY SIZE

124_{kWh}

POWER/TORQUE

129_{kW} / 430_{Nm}

- Zero Exhaust Emissions
- Extended range

ECANTER SPECIFICATIONS

MODEL	WHEEL BASE	GVM (optional)	GCM (optional)
A 4X2 8.55T XLWB FECXKHRESFAC	4450mm	8550kg	
B 4X2 8.55T XXLWB FECXKKRESFAC	4750mm	8550kg	

Electric Drive/Motor

Type	Permanent magnet synchronous motor S40
Power	129kW peak / 110kW continuous
Torque	430Nm peak / 250Nm continuous
Cooling	Coolant and water mix

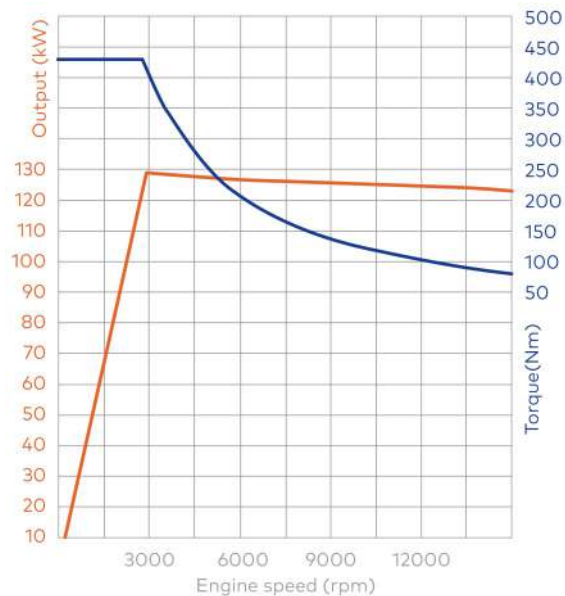

High Voltage Battery

Type	LFP lithium iron phosphate
Capacity	124kWh / 3 battery pack
Cooling	Water & Coolant mix
Charging	CCS2
AC Charging	up to 22kW (6hrs)
DC Charging	up to 104kW (1.3hrs)
Notes	*Charging times are based on theoretical numbers

Electrical

Voltage	12V / 24V with Battery Equalizer
Battery Capacity	24V 80Ah + 60Ah with equalizer for Body Builder
Headlamp Type	LED
Taillamp Type	LED
Daytime Running Lamps	LED

Transmission

Version	Single Reduction Gearbox
Type/Speeds	1 speed
Features	No Gear Changes In-Dash Gear Lever
Ratios	1:1.9:5.28

Front Axle

Type	Reverse Elliot 'I' Beam
Capacity *	3400kg
Notes	*See MAX LOADING for vehicle capacity.

Front Suspension

Type	Laminated leaf springs with shock absorbers and stabilizer
------	--

Rear Axle

Type	De Dion tube (eAxle)
Capacity*	6000kg
Notes	*See MAX LOADING for vehicle capacity.

Rear Suspension

Type	Laminated leaf springs with shock absorbers
------	---

Max Loading

Front	3400kg
Rear	6000kg
Total	8550kg

Options

Options	Q05 - ePTO Flange system + Cab back control Q06 - ePTO Pulley system + Cab back control
---------	--

Steering

Type	Integral Power Assisted Ball and Nut
Steering Column	Tilt/Telescopic Adjustable with Lock

Brakes

Type	Hydraulic Dual Circuit with Front and Rear Discs
Features	ABS plus EBD Electronic Brake Distribution ABA5 Active Brake Assist 5
Park Brake	Electric park brake - disc park brake
Auxiliary	4 Stage regenerative brake

Wheels & Tyres

Wheel Type	Steel Disc Rims
Wheel Size	19.5X6.75-129-11
Wheel Stud Pattern	6 Stud
Tyre Size All	225/70R19.5
Spare Tyre Carrier	Provided
Spare Tyre	Provided

Chassis

Type	Ladder frame, channel section with reinforcement and crossmembers
Width	850mm

Instruments

Gauges	New Digital Display Speedometer Braking Mode Battery Percentage Range Temperature
--------	--

Standard Features

Airbag(s)	Dual Air Bags and Seat Belt Pre-Tensioners (Driver & Far Side Passenger)
Cab Cooling & Heating	Air Conditioner / Heater / Demister
Accessory Power	12V Accessory Power Outlet / Cigar Lighter
Driving	Fuso Multimedia Unit Keyless Central Locking Electric Windows Cup Holders 2

ECANTER SPECIFICATIONS

	MODEL	WHEEL BASE	GVM (optional)	GCM (optional)
A	4X2 8.55T XLWB FECXKHRESFAC	4450mm	8550kg	
B	4X2 8.55T XXLWB FECXKKRESFAC	4750mm	8550kg	

Cab Features	
Type	All Steel Forward Control Manual Tilt
Cab Structure	ECE-R29 Standard
Colour	Natural White
Interior	Fully Trimmed
Windscreen	Laminated Tinted
Windscreen Wipers	2 Speed + Intermittent Cycle with Integrated Washer Nozzles
Rear Vision Mirrors	Short and wide split mirrors
Seating Capacity	3
Seat Belts	2 x 3 point seat belts 1 x 2 point lap sash
Seat (driver)	ISRI Suspended with Weight Adjustment, LH Arm Rest and Lumbar Support
Seats (passenger)	Flat Folding, ISRI 2 Passenger Fixed Seat

Active Safety	
Safety Systems	ABA5 - Active Brake Assist 5 ASGA - Active Sideguard Assist AVAS - Acoustic Vehicle Alerting System HSA - Hill Start Assist LDWS - Lane Departure Warning System ESP - Electronic Stability Program ABS plus EBD - Anti-lock Braking System plus Electronic Brake Distribution LED Head lamps and Tail lamps DRL - Daytime Running Lamps IHC - Intelligent Headlight Control High Voltage Interlock Loop
Reverse Warning	Buzzer
Notes	Active Safety Systems primary function is to provide driver assistance to increase road safety in events of driver inattentiveness. These systems do not allow for lack of attention whilst driving and should not replace safe and alert driving.

Passive Safety	
Airbags	SRS Airbag - Driver and Far Side Passenger
Body Strength	ECE-R29 Cab Strength Compliant
Emergency Operational Decals	Internal & External
Seat Belts - Driver & Driver Assistant	3 Point ELR Lap Sash

Service Intervals	
Interval*	30,000km or 12 Months (whichever occurs first)

Warranty*	
Basic/Powertrain	5 Years / 200,000kms
	8 Years / 200,000kms HV Battery Only
Notes	* Please refer to Fuso Owners Warranty Booklet for additional terms and conditions.

Performance		
Turning Circle (kerb to kerb - metres)	A	B
	16.6	17.6
Electronically Speed Limited to:	100km/hr	
Gradeability at Rated GVM (theoretical)*	20%	
Notes	*This is theoretical performance only. Actual performance may vary under different conditions	

Mass estimated*		
Front*	A	B
	2080kg	2115kg
Rear*	A	B
	1880kg	1860kg
Total*	A	B
	3960kg	3975kg
Notes	* Mass est. includes weight of oil, coolant, spare tyre carrier & bracket, spare tyre & disc wheel. Weights provided are subject to 3.5% variation +/-	

Dimensions mm		
WFF (Width Front Fender) (mm)	1995	
WRA (Width Rear Axle) (mm)	2155	
WFT (Width Front Track) (mm)	1665	
WRT (Width Rear Track) (mm)	1660	
Width Frame (mm)	850	
A - Length Overall (mm)	A	B
	7185	7735
C - Front Overhang (mm)	1140	
D - Wheelbase (mm)	A	B
	4450	4750
G - Front Axle to Rear of Cab (mm)	525	
H - Rear of Cab to Rearmost Item Behind Cab (mm)	90	
I - Rearmost Item Behind Cab to Rear Axle (mm)	A	B
	3835	4135
J - Frame, Rear Axle to End (mm)	A	B
	1595	1845
P - Height Cab to Ground (mm)	A	B
	2285	2280
Q - Height Cab to Frame (mm)	1505	
R - Height Rear Frame to Ground (mm)	846	

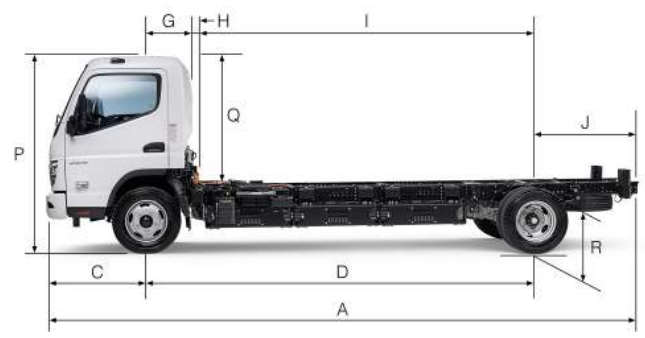

ECANTER SPECIFICATIONS

	MODEL	WHEEL BASE	GVM (optional)	GCM (optional)
A	4X2 8.55T XLWB FECXKHRESFAC	4450mm	8550kg	
B	4X2 8.55T XXLWB FECXKKRESFAC	4750mm	8550kg	



Call 1800 033 557

or visit fuso.com.au

Unless specified in writing herein the accessories, applications, bodies or equipment depicted in this are for illustration purposes only and may not be available from Daimler Truck Australia Pacific Pty Ltd. ABN 86 618 413 282 DTAuP. No representation or warranty whatsoever is given in relation to any accessories, applications, bodies or equipment or suitability of same that are shown herein that may be manufactured, supplied or fitted by a party other than DTAuP. DTAuP reserves the right without notice or obligation to discontinue or make changes to the colour, designs, materials and specifications of the products and options referred to herein at any time. For the most current information and in order to ascertain which accessories, applications, bodies and equipment are available from DTAuP please contact your authorised FUSO dealer. Fuso is a registered trademark of Daimler Truck Australia Pacific Pty Ltd. Copyright DTAuP. Reproduction in whole or part prohibited without written approval. Valid from 20-Jun-23.